



PROHLÁŠENÍ O VLASTNOSTECH



č. 0015 – CS

1. Jedinečný identifikační kód typu výrobku: **svorníková kotva fischer FBN II, FBN II A4**
2. Zamýšlené/zamýšlená použití:

Výrobek	Zamýšlené/zamýšlená použití
Expanzní kotva řízená kroutícím momentem	Dodatečné upevnění v tlačené zóně betonu, viz. doplněk, obzvláště Přílohy B 1 - B 3

3. Výrobce: **fischerwerke GmbH & Co. KG, Klaus-Fischer-Straße 1, 72178 Waldachtal, Německo**
4. Zplnomocněný zástupce: --
5. Systém/systémy POSV: **1**
- 6a. Harmonizovaná norma: ---

Oznámený subjekt/oznámené subjekty: ---

- 6b. Evropský dokument pro posuzování: **ETAG 001; 2013-04**

Evropské technické posouzení: **ETA-07/0211; 2016-05-19**

Subjekt pro technické posuzování: **DIBt**

Oznámený subjekt/oznámené subjekty: **1343 – MPA Darmstadt**

7. Deklarovaná vlastnost/Deklarované vlastnosti:

Mechanická odolnost a stabilita (BWR 1)

Základní vlastnosti	Výkon
Charakteristická únosnost v tahu a ve smyku	Viz. doplněk, obzvláště Přílohy C 1 a C 2
Vzdálenost k okraji a osová vzdálenost	Viz. doplněk, obzvláště Přílohy C 1 a C 2
Posuny při zatížení tahem a smykem	Viz. doplněk, obzvláště Příloha C 3

Bezpečnost v případě požáru (BWR 2)

Základní vlastnosti	Výkon
Odolnost proti ohni	Kotvení splňuje požadavky Třídy A 1
Požární odolnost	VNS

8. Příslušná technická dokumentace a/nebo specifická technická dokumentace: ---

Vlastnosti výše uvedeného výrobku jsou ve shodě se souborem deklarováných vlastností. Toto prohlášení o vlastnostech se v souladu s nařízením (EU) č. 305/2011 vydává na výhradní odpovědnost výrobce uvedeného výše.

Podepsáno za výrobce a jeho jménem:

Andreas Bucher, Dipl.-Ing.

Wolfgang Hengesbach, Dipl.-Ing., Dipl.-Wirtsch.-Ing.

Tumlingen, 2016-05-25

- Toto PoV bylo připraveno v různých jazykových mutacích.. V případě rozporu vždy rozhoduje interpretace verze v anglickém jazyce.

- Příloha obsahuje nepovinné a doplňkové informace v anglickém jazyce na rámec zákonných požadavků.

Specific Part

1 Technical description of the product

The Fischer Bolt anchor FBN II and FBN II A4 is an anchor made of zinc plated, hot-dip galvanised or stainless steel which is placed into a drilled hole and anchored by torque-controlled expansion.

Product and product description is given in Annex A.

2 Specification of the intended use in accordance with the applicable European Assessment Document

The performances given in Section 3 are only valid if the anchor is used in compliance with the specifications and conditions given in Annex B.

The verifications and assessment methods on which this European Technical Assessment is based lead to the assumption of a working life of the anchor of at least 50 years. The indications given on the working life cannot be interpreted as a guarantee given by the producer, but are to be regarded only as a means for choosing the right products in relation to the expected economically reasonable working life of the works.

3 Performance of the product and references to the methods used for its assessment

3.1 Mechanical resistance and stability (BWR 1)

Essential characteristic	Performance
Characteristic resistance for tension and shear loads in concrete	See Annex C 1 and C 2
Edge distances and spacing	See Annex C 1 and C 2
Displacements under tension and shear loads	See Annex C 3

3.2 Safety in case of fire (BWR 2)

Essential characteristic	Performance
Reaction to fire	Anchorage satisfy requirements for Class A1
Resistance to fire	No performance determined (NPD)

3.3 Safety in use (BWR 4)

The essential characteristics regarding Safety in use are included under the Basic Works Requirement Mechanical resistance and stability.

4 Assessment and verification of constancy of performance (AVCP) system applied, with reference to its legal base

In accordance with guideline for European technical approval ETAG 001, April 2013 used as European Assessment Document (EAD) according to Article 66 Paragraph 3 of Regulation (EU) No 305/2011 the applicable European legal act is: [96/582/EC].

The system to be applied is: 1

Cone bolt manufactured by cold - forming:

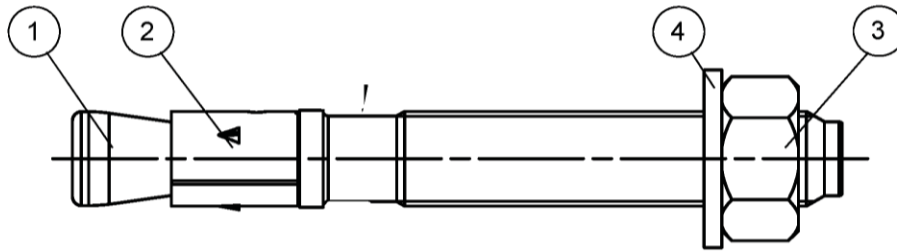

Cone bolt manufactured by turning:

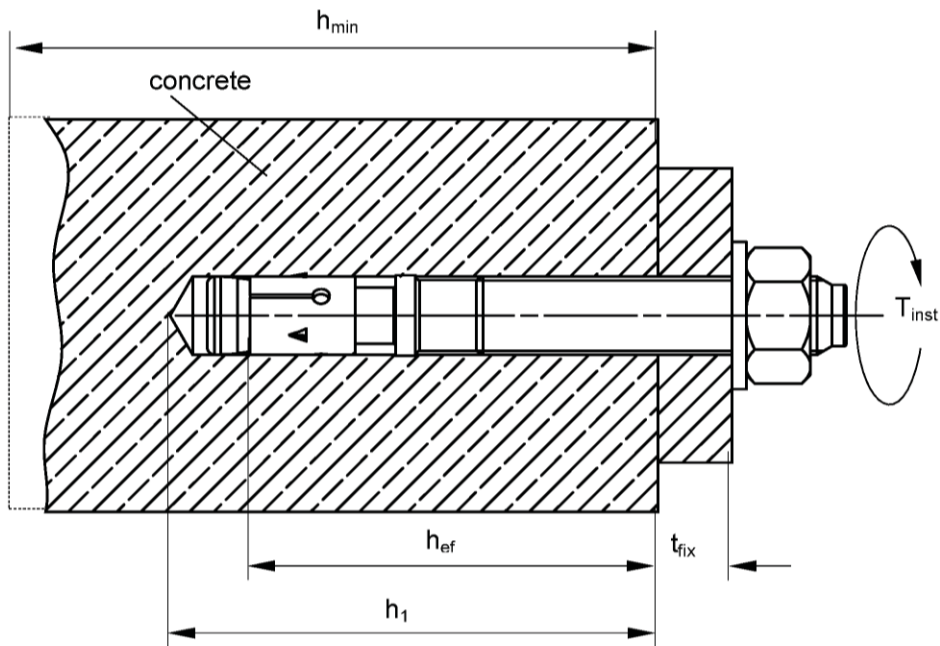
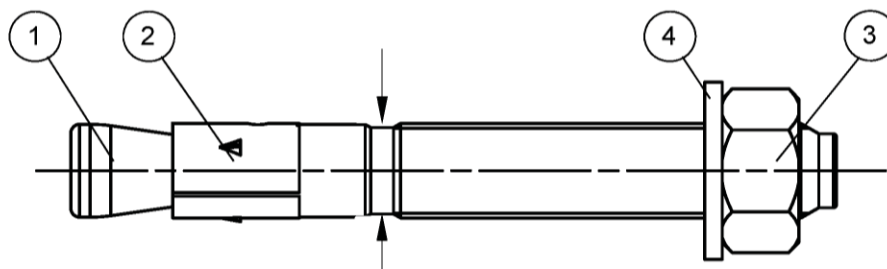

- ① Cone bolt (cold – formed or turned)
- ② Expansion sleeve
- ③ Hexagon nut
- ④ Washer

- h_{ef} = Effective anchorage depth
- t_{fix} = Thickness of fixture
- h_1 = Drill hole depth
- h_{min} = Thickness of concrete member
- T_{inst} = Required torque moment

fischer Bolt Anchor FBN II, FBN II A4

Product description
Installed condition

Annex A 1

FBN II for use with standard and reduced anchorage depth ($h_{ef, sta}$ and $h_{ef, red}$)

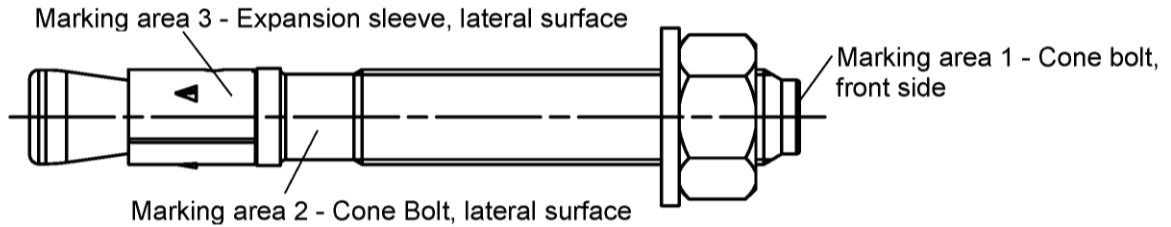

Product marking, example:



works symbol | type of anchor placed on marking area 2 or marking area 3

thread size / thickness of fixture (t_{fix}) for $h_{ef, sta}$ identification A4 placed on marking area 2

Table A1: Letter-code on marking area 1 and maximum thickness of fixture t_{fix} :

marking		A	B	C	D	E	F	G	H	I	K	L	M	N	O	P	R	S	T	U	V	W	X	Y	Z
max. t_{fix} for $h_{ef, sta}$	M6-M20	5	10	15	20	25	30	35	40	45	50	60	70	80	90	100	120	140	160	180	200	250	300	350	400
max. t_{fix} for $h_{ef, red}$	M8, M10	15	20	25	30	35	40	45	50	55	60	70	80	90	100	110	130	150	170	190	210	260	310	360	410
	M12, 16	20	25	30	35	40	45	50	55	60	65	75	85	95	105	115	135	155	175	195	215	265	315	365	415
	M20	30	35	40	45	50	55	60	65	70	75	85	95	105	115	125	145	165	185	205	225	275	325	375	425

FBN II K for use with reduced anchorage depth only ($h_{ef, red}$):

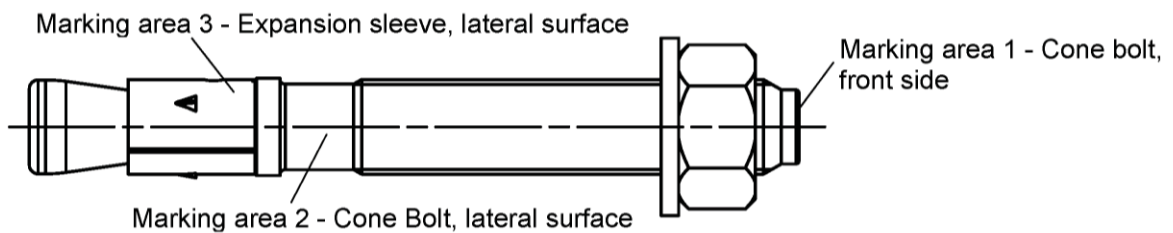

Product marking, example:

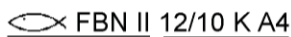

works symbol | type of anchor placed on marking area 2 or marking area 3

thread size / thickness of fixture (t_{fix}) identification K for $h_{ef, red}$ | identification A4 placed on marking area 2

Table A2: Letter-code on marking area 1 and maximum thickness of fixture t_{fix} :

marking		-A-	-B-	-C-	-D-	-E-	-F-	-G-	-H-	-I-	-K-	-L-	-M-	-N-	-O-	-P-	-R-	-S-	-T-	-U-	-V-	-W-	-X-	-Y-	-Z-
max. t_{fix} for $h_{ef, red}$	M8-M20	5	10	15	20	25	30	35	40	45	50	60	70	80	90	100	120	140	160	180	200	250	300	350	400

Identification for $h_{ef, red}$ is the letter-code between 2 hyphen

fischer Bolt Anchor FBN II, FBN II A4

Product description
Anchor Types

Annex A 2

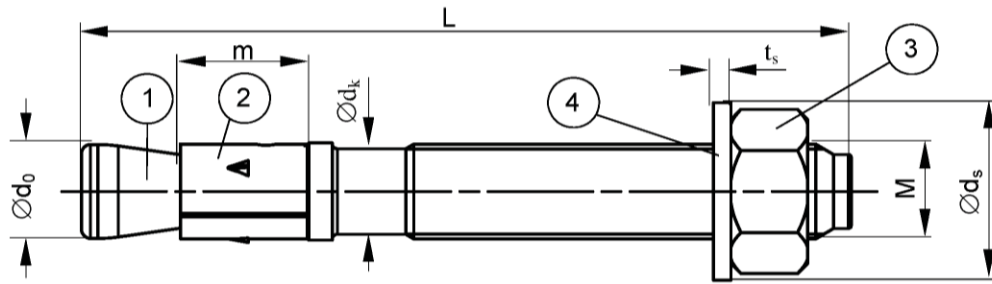

Table A3: Anchor dimensions [mm]

Part	Designation		FBN II, FBN II A4						
			M6	M8	M10	M12	M16	M20	
1	Cone bolt	M	=	M6	M8	M10	M12	M16	M20
		Ø d ₀	=	5,9	7,9	9,9	11,9	15,9	19,6
		Ø d _k	=	5,2	7,1	8,9	10,8	14,5	18,2
2	Expansion sleeve	m	=	10	11,5	13,5	16,5	21,5	33,5
3	Hexagon nut	SW	=	10	13	17	19	24	30
4	Washer	t _s	≥	1,0	1,4	1,8	2,3	2,7	2,7
		Ø d _s	≥	11,5	15	19	23	29	36
Thickness of fixture		t _{fix}	≥	0	0	0	0	0	0
			≤	200	200	250	300	400	500
Length of anchor		L _{min}	-	45	56	71	86	120	139
		L _{max}	-	245	261	316	396	520	654

fischer Bolt Anchor FBN II, FBN II A4

Product description
Anchor dimensions

Annex A 3

Table A4: Materials FBN II (zinc plated $\geq 5\mu\text{m}$, DIN EN ISO 4042: 2001-01)

Part	Designation	Material
1	Cone bolt	Cold form steel or free cutting steel Nominal steel tensile strength $f_{uk} \leq 1000 \text{ N/mm}^2$ Nominal yield strength FBN II 8 - 16 $f_{yk} \geq 560 \text{ N/mm}^2$ ¹⁾
2	Expansion sleeve	Cold strip, EN 10139:2013 ²⁾
3	Hexagon nut	Steel, property class min. 8, EN ISO 898-2:2012
4	Washer	Cold strip, EN 10139:2013

¹⁾ FBN II 6 $f_{yk} \geq 480 \text{ N/mm}^2$, FBN II 20 $f_{yk} \geq 520 \text{ N/mm}^2$

²⁾ Optional stainless steel EN 10088:2014

Table A5: Materials FBN II (hot-dip galvanized $\geq 50\mu\text{m}$, ISO 10684: 2004 ²⁾)

Part	Designation	Material
1	Cone bolt	Cold form steel or free cutting steel Nominal steel tensile strength $f_{uk} \leq 1000 \text{ N/mm}^2$ Nominal yield strength FBN II 8 - 16 $f_{yk} \geq 560 \text{ N/mm}^2$ ¹⁾
2	Expansion sleeve	Stainless steel EN 10088:2014
3	Hexagon nut	Steel, property class min. 8, EN ISO 898-2:2012
4	Washer	Cold strip, EN 10139:2013

¹⁾ FBN II 6 $f_{yk} \geq 480 \text{ N/mm}^2$, FBN II 20 $f_{yk} \geq 520 \text{ N/mm}^2$

²⁾ Alternative method sherardized $\geq 50 \mu\text{m}$, EN 13811:2003

Table A6: Materials FBN II A4

Part	Designation	Material
1	Cone bolt	Stainless steel EN 10088:2014 Nominal steel tensile strength $f_{uk} \leq 1000 \text{ N/mm}^2$ Nominal yield strength FBN II 8 - 20 $f_{yk} \geq 560 \text{ N/mm}^2$ ¹⁾
2	Expansion sleeve	Stainless steel EN 10088:2014
3	Hexagon nut	Stainless steel EN 10088:2014 ISO 3506-2: 2009; property class min. 70
4	Washer	Stainless steel EN 10088:2014

¹⁾ FBN II 6 $f_{yk} \geq 480 \text{ N/mm}^2$

fischer Bolt Anchor FBN II, FBN II A4

Product description
Materials

Annex A 4

Specifications of intended use

fischer Bolt Anchor FBN II, FBN II A4		M6	M8	M10	M12	M16	M20
Material	Steel	Zinc plated		✓			
		Hot-dip galvanized		-	✓		
	Stainless steel	A4		✓			
Static and quasi-static loads				✓			
Reduced anchorage depth		-			✓		
Uncracked concrete				✓			

Base materials:

- Reinforced and unreinforced normal weight concrete according to EN 206-1:2000
- Strength classes C20/25 to C50/60 according to EN 206-1:2000

Use conditions (Environmental conditions):

- Structures subject to dry internal conditions (FBN II (zinc plated / hot-dip galvanized), FBN II A4)
- Structures subject to external atmospheric exposure (including industrial and marine environment) and to permanently damp internal condition, if no particular aggressive conditions exist (FBN II A4). Such particular aggressive conditions are e.g. permanent, alternating immersion in seawater or the splash zone of seawater, chloride atmosphere of indoor swimming pools or atmosphere with extreme chemical pollution (e.g. in desulphurization plants or road tunnels where de-icing materials are used)

Design:

- Anchorages are to be designed under the responsibility of an engineer experienced in anchorages and concrete work
- Verifiable calculation notes and drawings are to be prepared taking account of the loads to be anchored. The position of the anchor is indicated on the design drawings (e.g. position of the anchor relative to reinforcement or to supports, etc.)
- Anchorages under static or quasi-static actions are to be designed in accordance with:
 - ETAG 001, Annex C, design method A, Edition August 2010 or
 - CEN/TS 1992-4:2009, design method A

Installation:

- Anchor installation carried out by appropriately qualified personnel and under the supervision of the person responsible for technical matters of the site
- Hammer or hollow drilling according to Annex B3
- In case of aborted hole: New hole must be drilled at a minimum distance of twice the depth of the aborted hole or closer, if the hole is filled with a high strength mortar and only if the hole is not in the direction of the oblique tensile or shear load

fischer Bolt Anchor FBN II, FBN II A4

Intended Use
Specifications

Annex B 1

Table B1: Installation parameters

Type of anchor / size FBN II, FBN II A4		M6	M8	M10	M12	M16	M20
Nominal drill hole diameter	$d_0 =$ [mm]	6	8	10	12	16	20
Cutting diameter of drill bit	$d_{cut} \leq$ [mm]	6,45	8,45	10,45	12,5	16,5	20,55
Effective anchorage depth	$h_{ef} =$ [mm]	30 ²⁾	40 (30 ¹⁾²⁾	50 (40 ¹⁾)	65 (50 ¹⁾)	80 (65 ¹⁾)	105 (80 ¹⁾)
Depth of drill hole in concrete	$h_1 \geq$ [mm]	40	56 (46 ¹⁾²⁾)	68 (58 ¹⁾)	85 (70 ¹⁾)	104 (89 ¹⁾)	135 (110 ¹⁾)
Diameter of clearance hole in the fixture	$d_f \leq$ [mm]	7	9	12	14	18	22
Required torque moment FBN II (zinc plated)	$T_{inst} =$ [Nm]	4	15	30	50	100	200
Required torque moment FBN II (hot-dip galvanized)	$T_{inst} =$ [Nm]	-	15	30	40	70	200
Required torque moment FBN II A4	$T_{inst} =$ [Nm]	4	10	20	35	80	150

¹⁾ Values for reduced anchorage depth

²⁾ Use restricted to anchoring of structural components which are statically indeterminate

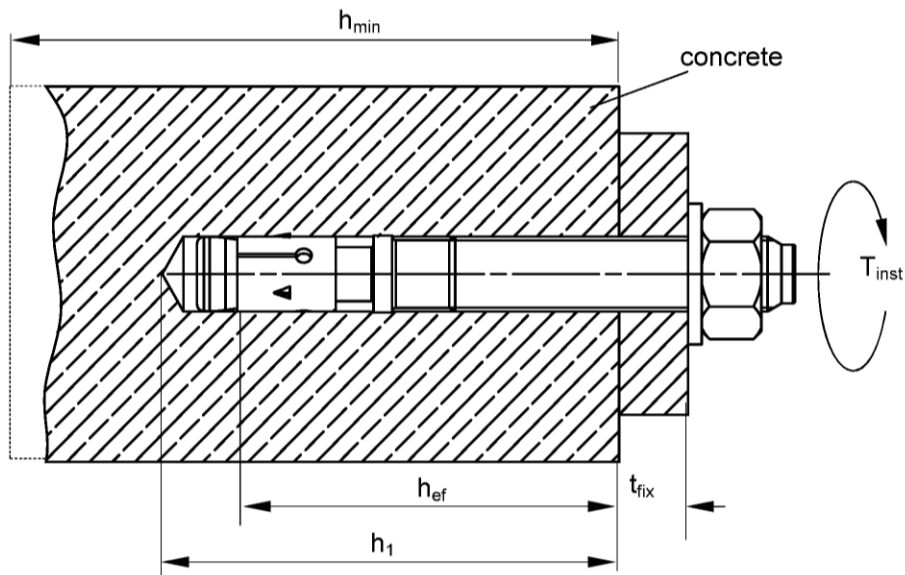

- h_{ef} = Effective anchorage depth
- t_{fix} = Thickness of fixture
- h_1 = Drill hole depth
- h_{min} = Thickness of concrete member
- T_{inst} = Required torque moment

fischer Bolt Anchor FBN II, FBN II A4

Intended Use
Installation instructions

Annex B 2

Table B2: Minimum thickness of concrete members, minimum spacing and minimum edge distance

Type of anchor / size FBN II, FBN II A4			M6	M8	M10	M12	M16	M20
Standard anchorage depth	Effective anchorage depth	$h_{ef, sta}$ [mm]	30 ²⁾	40	50	65	80	105
	Minimum thickness of member	h_{min} [mm]	100	100	100	120	160	200
	Minimum spacing	s_{min} [mm]	40	40	50 (70 ¹⁾)	70	90 (120 ¹⁾)	120
	Minimum edge distance	c_{min} [mm]	40	40 (45 ¹⁾)	50 (55 ¹⁾)	70	90 (80 ¹⁾)	120
Reduced anchorage depth	Effective anchorage depth	$h_{ef, red}$ [mm]	-	30 ²⁾	40	50	65	80
	Minimum thickness of member	h_{min} [mm]	-	100	100	100	120	160
	Minimum spacing	s_{min} [mm]	-	40 (50 ¹⁾)	50	70	90	120 (140 ¹⁾)
	Minimum edge distance	c_{min} [mm]	-	40 (45 ¹⁾)	80	100	120	120

¹⁾ Values for FBN II A4

²⁾ Use restricted to anchoring of structural components which are statically indeterminate

Installation instructions

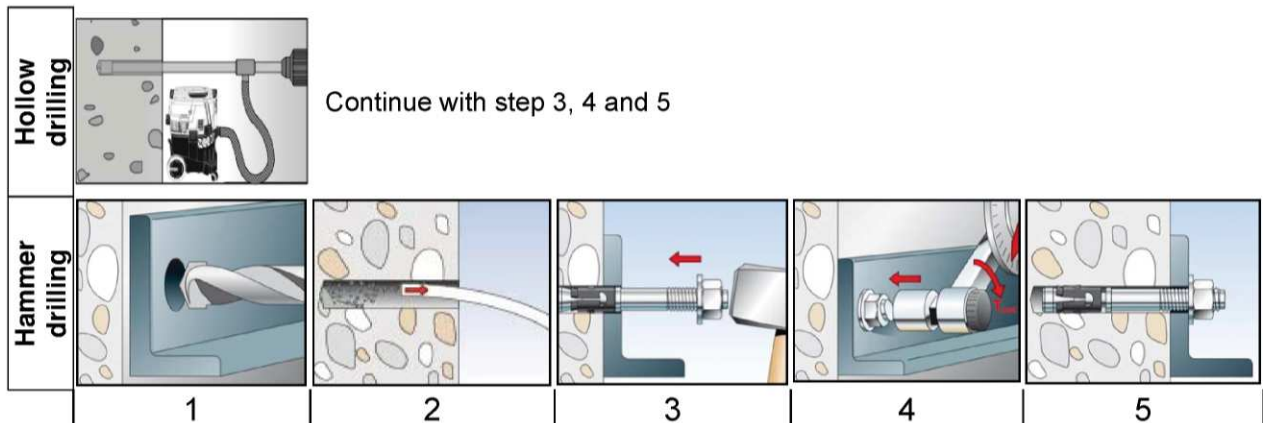

No.	Description	
1	Create drill hole with hammer drill	Create drill hole with hollow drill and vacuum cleaner
2	Clean bore hole	-
3	Set anchor	
4	Expand anchor with prescribed installation torque T_{inst}	
5	Finished installation	

Types of drills	
Hammer drill	
Hollow drill	

fischer Bolt Anchor FBN II, FBN II A4

Intended Use
Minimum spacing and edge distance
Installation instructions

Annex B 3

Table C1: Characteristic values of **tension** resistance for **standard and reduced anchorage depth** under static and quasi-static action (Design method A, according to **ETAG 001, Annex C** or **CEN/TS 1992-4:2009**)

Type of anchor / size			M6	M8	M10	M12	M16	M20
Steel failure for standard and reduced anchorage depth FBN II								
Characteristic resistance FBN II	$N_{Rk,s}$	[kN]	8,3	16,5	27,2	41,6	77,9	107
Partial safety factor	γ_{Ms}	[-]	1,5	1,4	1,4	1,4	1,5	1,5
Steel failure for standard and reduced anchorage depth FBN II A4								
Characteristic resistance FBN II A4	$N_{Rk,s}$	[kN]	10,6	16,5	27,2	41,6	78	111
Partial safety factor	γ_{Ms}	[-]	1,5	1,4	1,4	1,4	1,4	1,5
Pullout failure for standard anchorage depth FBN II, FBN II A4								
Characteristic resistance C20/25	$N_{Rk,p}$	[kN]	6 ⁴⁾	- ³⁾				
Pullout failure for reduced anchorage depth FBN II, FBN II A4								
Characteristic resistance C20/25	$N_{Rk,p}$	[kN]	-	6 ⁴⁾	- ³⁾			
Increasing factors for $N_{Rk,p}$	ψ_c	C25/30	1,10					
		C30/37	1,22					
		C35/45	1,34					
		C40/50	1,41					
		C45/55	1,48					
		C50/60	1,55					
Installation safety factor	$\gamma_2^1 = \gamma_{inst}^2$	[-]	1,0					
Concrete cone and splitting failure for standard anchorage depth FBN II, FBN II A4								
Effective anchorage depth	$h_{ef, sta}$	[mm]	30 ⁴⁾	40	50	65	80	105
Factor for uncracked concrete	$k_{ucr}^2)$	[-]	10,1					
Spacing	$s_{cr,N}$	[mm]	3 $h_{ef, sta}$					
Edge distance	$c_{cr,N}$	[mm]	1,5 $h_{ef, sta}$					
Spacing (splitting failure)	$s_{cr,sp}$	[mm]	130 ⁴⁾	190	200	290	350	370
Edge distance (splitting failure)	$c_{cr,sp}$	[mm]	65 ⁴⁾	95	100	145	175	185
Concrete cone and splitting failure for reduced anchorage depth FBN II, FBN II A4								
Effective anchorage depth	$h_{ef, red}$	[mm]	-	30 ⁴⁾	40	50	65	80
Factor for uncracked concrete	$k_{ucr}^2)$	[-]	10,1					
Spacing	$s_{cr,N}$	[mm]	3 $h_{ef, red}$					
Edge distance	$c_{cr,N}$	[mm]	1,5 $h_{ef, red}$					
Spacing (splitting failure)	$s_{cr,sp}$	[mm]	-	190 ⁴⁾	200	290	350	370
Edge distance (splitting failure)	$c_{cr,sp}$	[mm]	-	95 ⁴⁾	100	145	175	185

¹⁾ Parameter relevant for design according to ETAG 001, Annex C

²⁾ Parameter relevant for design according to CEN/TS 1992-4:2009

³⁾ Pullout failure not relevant

⁴⁾ Use restricted to anchoring of structural components which are statically indeterminate

fischer Bolt Anchor FBN II, FBN II A4

Performances

Characteristic values of tension resistance for standard and reduced anchorage depth

Annex C 1

Table C2: Characteristic values of **shear resistance** for **standard and reduced anchorage depth** under static and quasi-static action (Design method A, according to **ETAG 001, Annex C** or **CEN/TS 1992-4:2009**)

Type of anchor / size			M6	M8	M10	M12	M16	M20
Steel failure without lever arm for standard and reduced anchorage depth								
Charact. resistance FBN II	$V_{Rk,s}$	[kN]	6,0	13,3	21,0	31,3	55,1	67
Steel failure without lever arm for standard and reduced anchorage depth								
Charact. resistance FBN II A4	$V_{Rk,s}$	[kN]	5,3	12,8	20,3	27,4	51	86
Steel failure with lever arm for standard anchorage depth								
Charact. bending moment FBN II	$M^0_{Rk,s}$	[Nm]	9,4 ³⁾	26,2	52,3	91,6	232,2	422
Steel failure with lever arm for standard anchorage depth								
Charact. bending moment FBN II A4	$M^0_{Rk,s}$	[Nm]	8 ³⁾	26	52	85	216	454
Steel failure with lever arm for reduced anchorage depth								
Charact. bending moment FBN II	$M^0_{Rk,s}$	[Nm]	-	19,9 ³⁾	45,9	90,0	226,9	349
Steel failure with lever arm for reduced anchorage depth								
Charact. bending moment FBN II A4	$M^0_{Rk,s}$	[Nm]	-	21 ³⁾	47	85	216	353
Partial safety factor steel failure	γ_{Ms}	[-]	1,25					
Factor for ductility	$k_2^{2)}$	[-]	1,0					
Concrete pryout failure for standard anchorage depth FBN II, FBN II A4								
Factor k according to ETAG 001, Annex C or k_3 according to CEN/TS 1992-4	$k^1=k_{(3)}^{2)}$	[-]	1,4 ³⁾	1,8	2,1	2,3	2,3	2,3
Installation safety factor	$\gamma_2^1 = \gamma_{inst}^{2)}$	[-]	1,0					
Concrete pryout failure for reduced anchorage depth FBN II, FBN II A4								
Factor k according to ETAG 001, Annex C or k_3 according to CEN/TS 1992-4	$k^1=k_{(3)}^{2)}$	[-]	-	1,8 ³⁾	2,1	2,3	2,3	2,3
Installation safety factor	$\gamma_2^1 = \gamma_{inst}^{2)}$	[-]	1,0					
Concrete edge failure for standard anchorage depth FBN II, FBN II A4								
Effective length of anchor	$l_{f,sta}$	[mm]	30 ³⁾	40	50	65	80	105
Effective diameter of anchor	d_{nom}	[mm]	6	8	10	12	16	20
Installation safety factor	$\gamma_2^1 = \gamma_{inst}^{2)}$	[-]	1,0					
Concrete edge failure for reduced anchorage depth FBN II, FBN II A4								
Effective length of anchor	$l_{f,red}$	[mm]	-	30 ³⁾	40	50	65	80
Effective diameter of anchor	d_{nom}	[mm]	-	8	10	12	16	20
Installation safety factor	$\gamma_2^1 = \gamma_{inst}^{2)}$	[-]	1,0					

¹⁾ Parameter relevant for design according to ETAG 001, Annex C

²⁾ Parameter relevant for design according to CEN/TS 1992-4:2009

³⁾ Use restricted to anchoring of structural components which are statically indeterminate

fischer Bolt Anchor FBN II, FBN II A4

Performances

Characteristic values of shear resistance for standard and reduced anchorage depth

Annex C 2

Table C3: Displacements due to tension loads

Type of anchor / size FBN II, FBN II A4			M6	M8	M10	M12	M16	M20
Standard anchorage depth	$h_{ef, sta}$	[mm]	30	40	50	65	80	105
Tension load C20/25	N	[kN]	2,8	6,1	8,5	12,6	17,2	25,8
Displacements	δ_{N0}	[mm]	1,9	0,6	0,9	1,5 (1,9 ¹⁾)	1,8	1,8 (2,0 ¹⁾)
	$\delta_{N\infty}$	[mm]	3,1 (2,7 ¹⁾)					
Reduced anchorage depth	$h_{ef, red}$	[mm]	-	30	40	50	65	80
Tension load C20/25	N	[kN]		2,8	6,1	8,5	12,6	17,2
Displacements	δ_{N0}	[mm]		0,4	0,7	0,7	0,9	1,0
	$\delta_{N\infty}$	[mm]		1,6 (1,7 ¹⁾)				

¹⁾ Values for FBN II A4

Table C4: Displacements due to shear loads

Type of anchor / size FBN II, FBN II A4			M6	M8	M10	M12	M16	M20
Shear load FBN II	V	[kN]	3,4	7,6	12,0	17,9	31,5	38,2
Displacements FBN II	δ_{V0}	[mm]	0,7	1,5	1,6	2,0	3,0	2,6
	$\delta_{V\infty}$	[mm]	1,1	2,3	2,4	3,0	4,5	3,9
Shear load FBN II A4	V	[kN]	3,0	7,3	11,6	15,7	29,1	49,0
Displacements FBN II A4	δ_{V0}	[mm]	1,5	1,4	2,1	2,6	2,7	4,6
	$\delta_{V\infty}$	[mm]	2,3	2,2	3,2	3,9	4,1	7,0

fischer Bolt Anchor FBN II, FBN II A4

Performances
Displacement under tension and shear loads

Annex C 3